

REVISIONS				
REV.	DESCRIPTION	ECO #	DATE	APPROVED
B3	MINOR CLAMP CHANGES	2013-185	Mar 22.13	
C1	ADDED LATEST CLAMP DESIGN	2013-360	9/4/2013	CNB

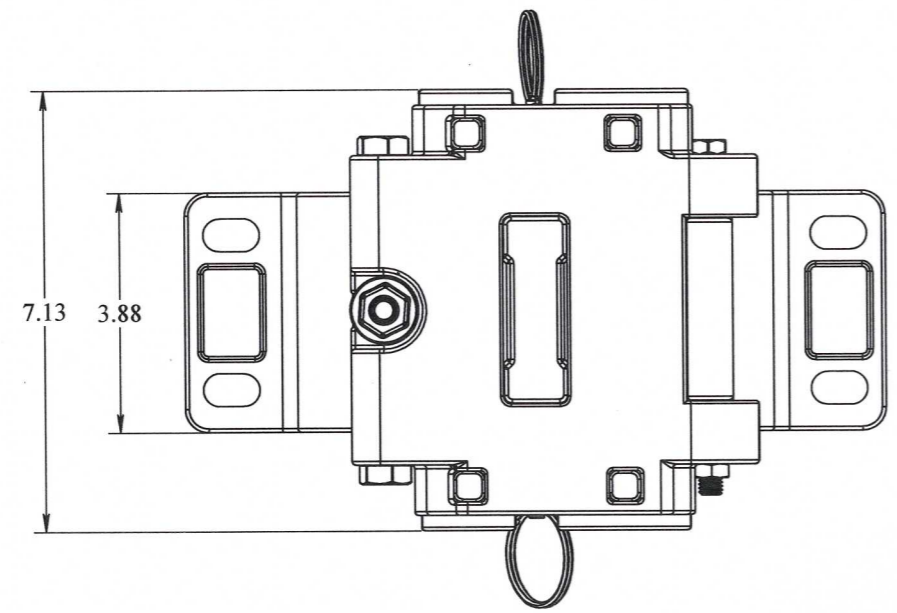

EXTENDED

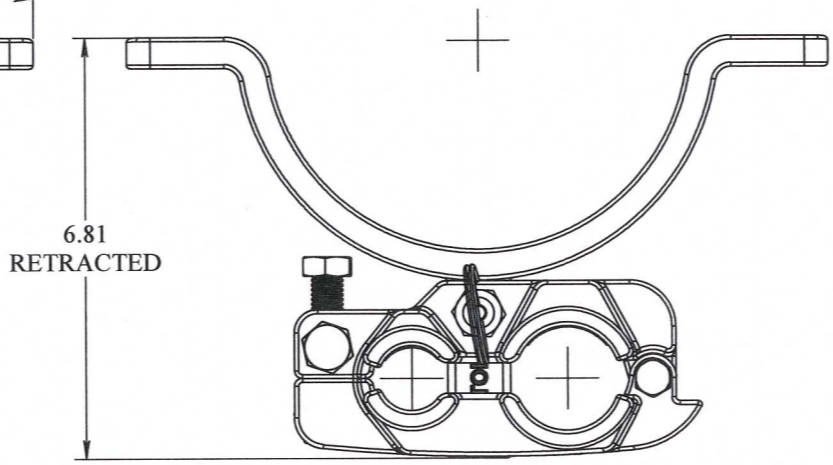
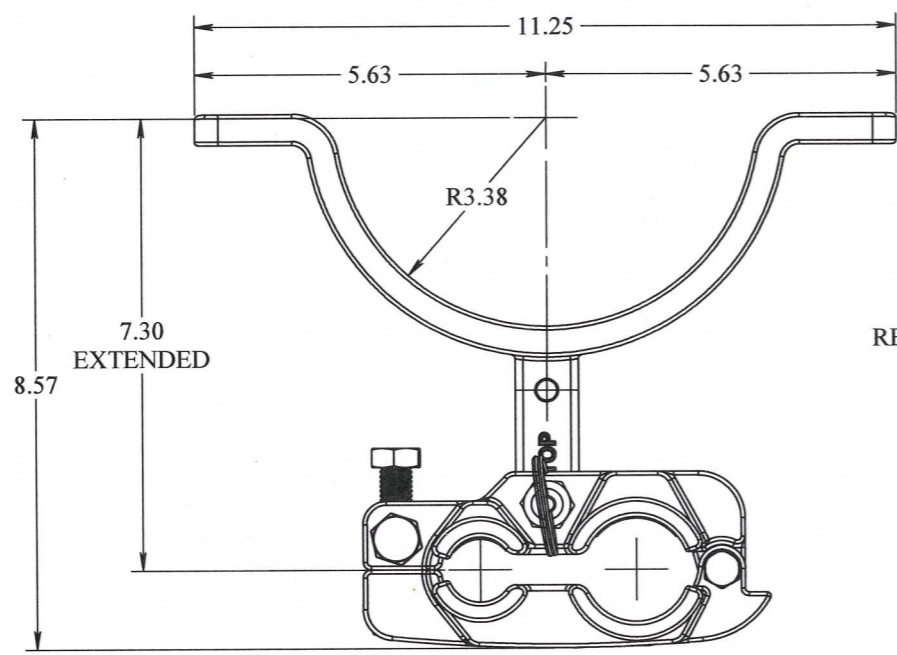

RETRACTED

PROPRIETARY AND CONFIDENTIAL:
 THE INFORMATION CONTAINED IN THIS DRAWING IS THE SOLE PROPERTY OF THE SUBSEA COMPANY INC. ANY REPRODUCTION IN PART OR AS A WHOLE WITHOUT THE WRITTEN PERMISSION OF THE SUBSEA COMPANY INC IS PROHIBITED.

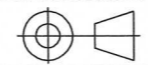
3RD ANGLE PROJECTION: 

INTERPRET GEOMETRIC TOLERANCING PER: ASME Y14.5

WORKMANSHIP STANDARD PER WI 751-001

UNLESS OTHERWISE SPECIFIED: ALL DIMENSIONS ARE IN INCHES

WEIGHT: 24.06 lbs.

NAME	DATE
CREG	9-5-13
CHEKED	9-5-13
Q.A.	9-12-13
MFG APPR.	9-10-13

SCALE: 1:4

DO NOT SCALE DRAWING

 **THE SUBSEA COMPANY INC**

SIZE **B** TITLE: RETRACTABLE/REMOVABLE MUX CLAMP ASSEMBLY REV **C1**

DWG. NO. TSC-01013-GA SHEET 1 OF 3

TOP DOWN VIEW SHOWING
RETRACTABLE MUX CLAMP
IN RELATION TO BOUYANCY
WHEN EXTENDED & RETRACTED.

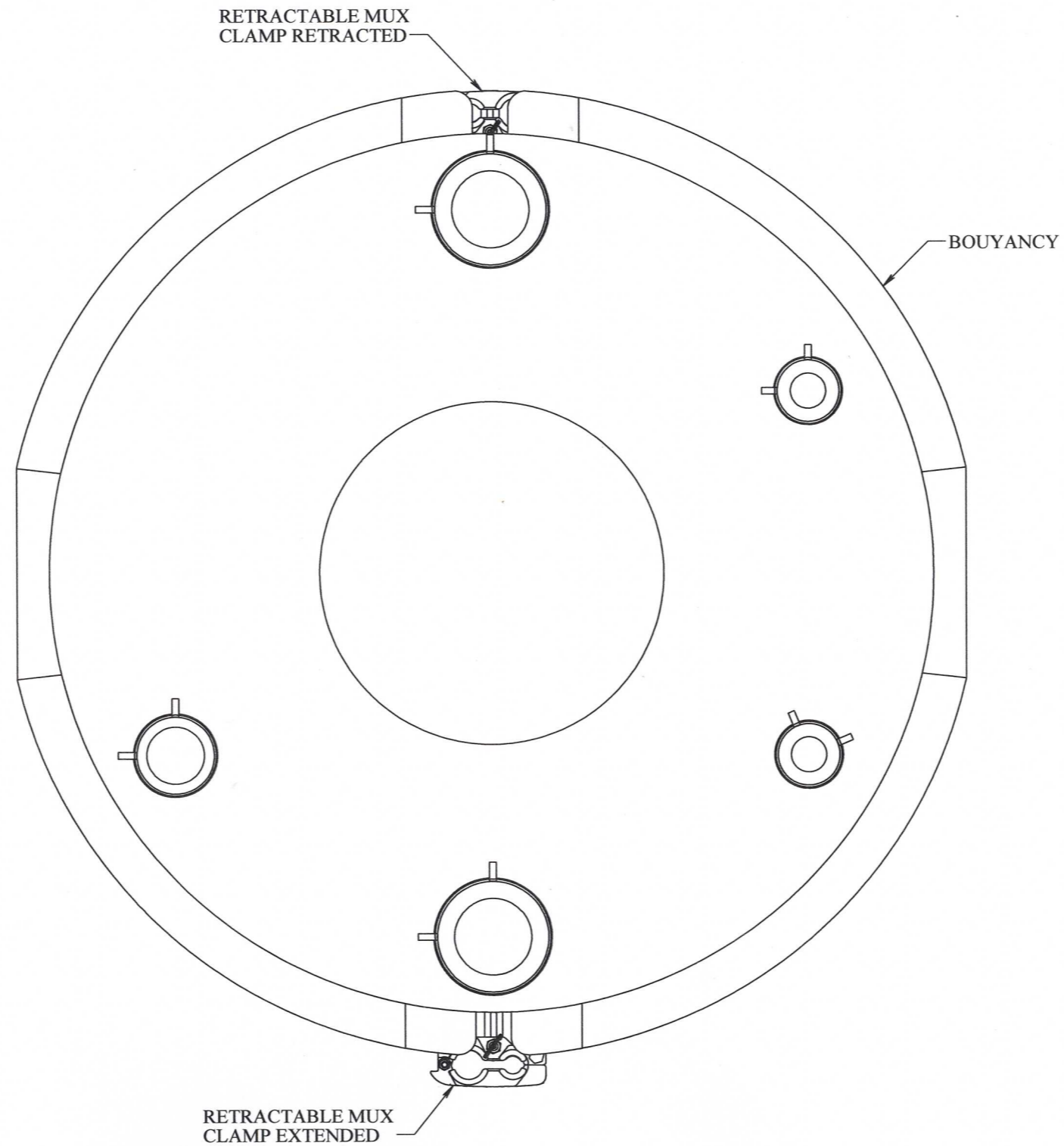

PROPRIETARY AND CONFIDENTIAL:
THE INFORMATION CONTAINED IN THIS DRAWING IS THE SOLE PROPERTY OF THE SUBSEA COMPANY INC. ANY REPRODUCTION IN PART OR AS A WHOLE WITHOUT THE WRITTEN PERMISSION OF THE SUBSEA COMPANY INC IS PROHIBITED.

WORKMANSHIP STANDARD
PER WI 751-001

	NAME	DATE
DRAWN	<i>Green</i>	9-5-13
CHECKED	<i>Cooley</i>	9-5-13
Q.A.	<i>CATES</i>	9-10-13
MFG APPR.	<i>PAINT</i>	9-10-13



THE SUBSEA COMPANY INC

UNLESS OTHERWISE SPECIFIED:
ALL DIMENSIONS ARE IN INCHES

SCALE: 1:4

SIZE
B

TITLE:
RETRACTABLE/REMOVABLE MUX CLAMP
ASSEMBLY

REV
C1

3RD ANGLE PROJECTION:

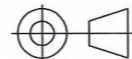

INTERPRET GEOMETRIC
TOLERANCING PER:
ASME Y14.5

WEIGHT: lbs.

DO NOT SCALE DRAWING

DWG. NO. TSC-01013-GA

SHEET 2 OF 3

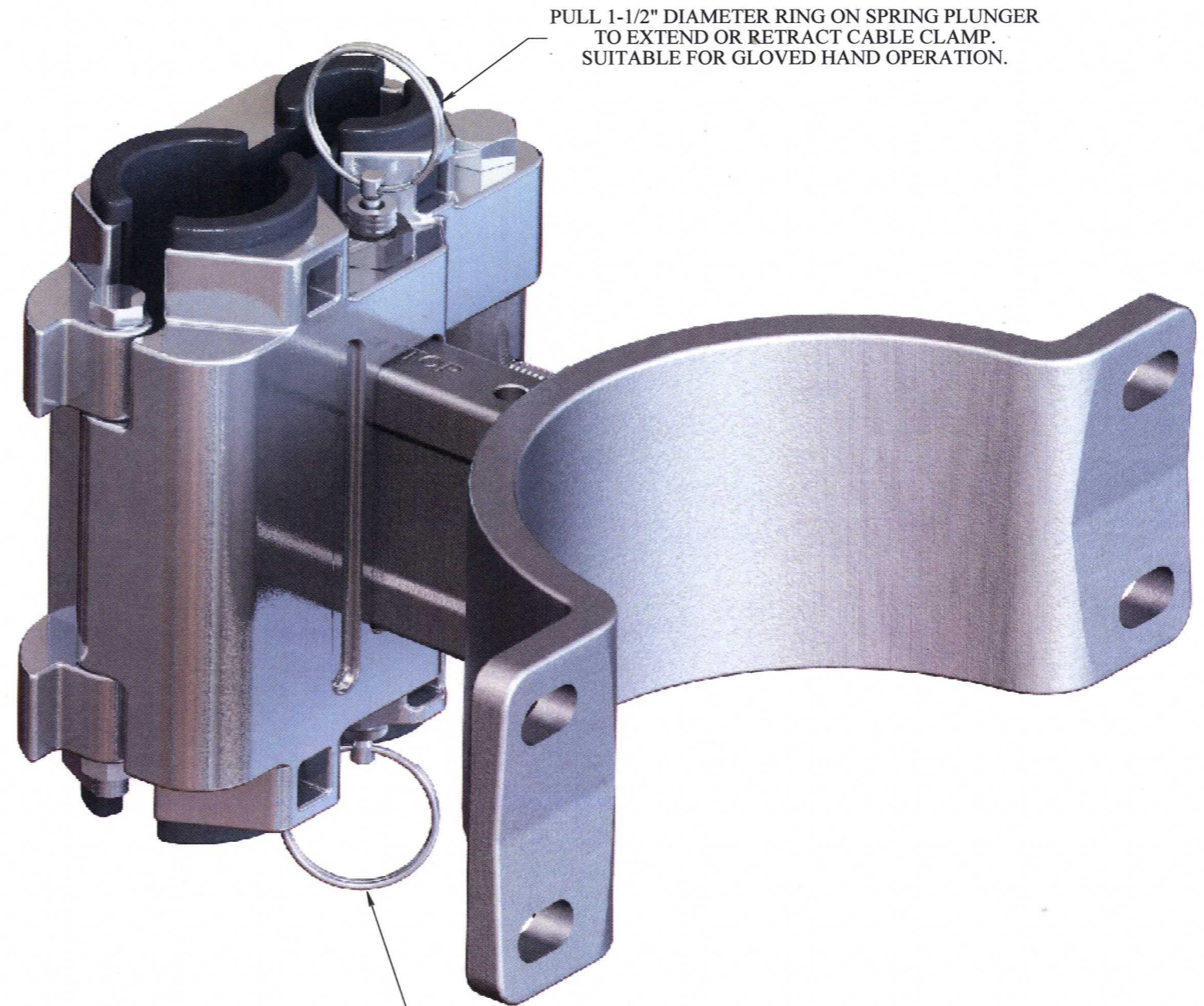
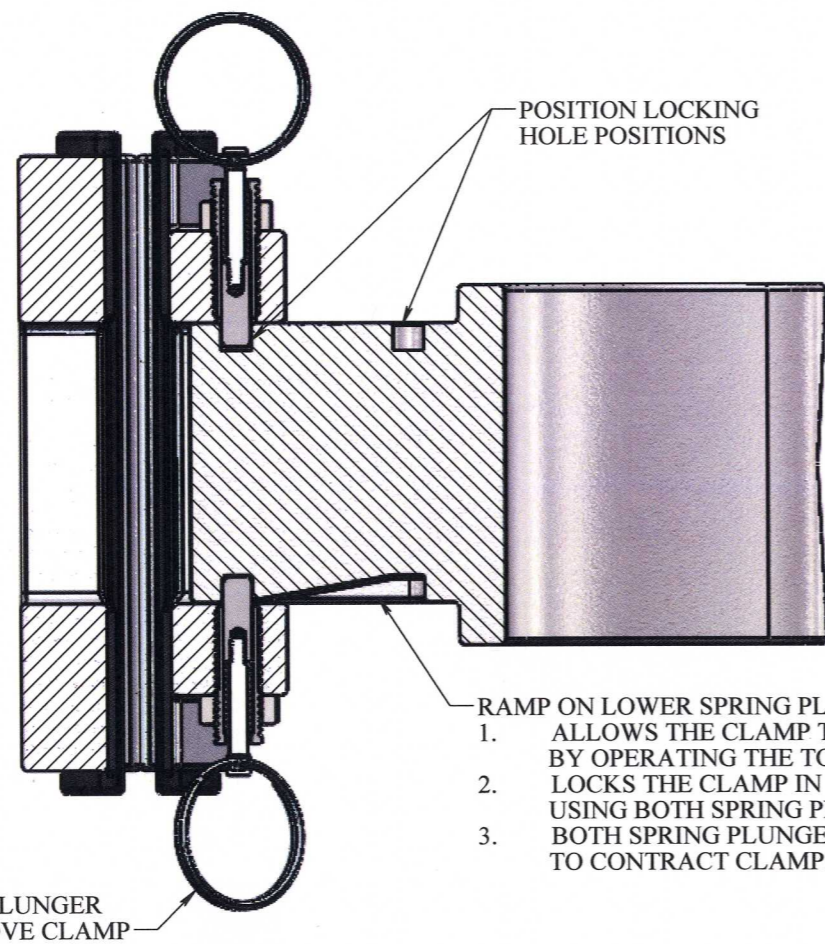

PROPRIETARY AND CONFIDENTIAL: THE INFORMATION CONTAINED IN THIS DRAWING IS THE SOLE PROPERTY OF THE SUBSEA COMPANY INC. ANY REPRODUCTION IN PART OR AS A WHOLE WITHOUT THE WRITTEN PERMISSION OF THE SUBSEA COMPANY INC IS PROHIBITED.	WORKMANSHIP STANDARD PER WI 751-001	<table border="1"> <tr> <th>NAME</th> <th>DATE</th> </tr> <tr> <td><i>C. REH</i></td> <td>9-5-13</td> </tr> <tr> <td><i>COHEN</i></td> <td>9-5-13</td> </tr> <tr> <td><i>Q.A.</i></td> <td><i>Q.A.S</i></td> </tr> <tr> <td><i>MFG APPR.</i></td> <td><i>9-10-13</i></td> </tr> </table>	NAME	DATE	<i>C. REH</i>	9-5-13	<i>COHEN</i>	9-5-13	<i>Q.A.</i>	<i>Q.A.S</i>	<i>MFG APPR.</i>	<i>9-10-13</i>	THE SUBSEA COMPANY INC	SIZE B	TITLE: RETRACTABLE/REMOVABLE MUX CLAMP ASSEMBLY	REV C1
	NAME	DATE														
	<i>C. REH</i>	9-5-13														
	<i>COHEN</i>	9-5-13														
<i>Q.A.</i>	<i>Q.A.S</i>															
<i>MFG APPR.</i>	<i>9-10-13</i>															
UNLESS OTHERWISE SPECIFIED: ALL DIMENSIONS ARE IN INCHES	SCALE: 1:4															
3RD ANGLE PROJECTION: 	INTERPRET GEOMETRIC TOLERANCING PER: ASME Y14.5	DO NOT SCALE DRAWING	DWG. NO. TSC-01013-GA	SHEET 3 OF 3												
WEIGHT: 11.77 lbs.																