

REVISIONS				
REV.	DESCRIPTION	ECO #	DATE	APPROVED
A1	RELEASE	2021-006	3/25/2021	

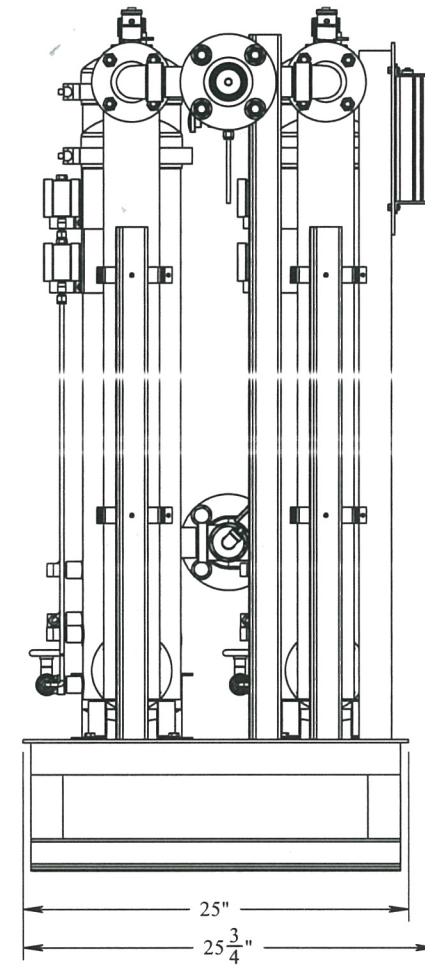
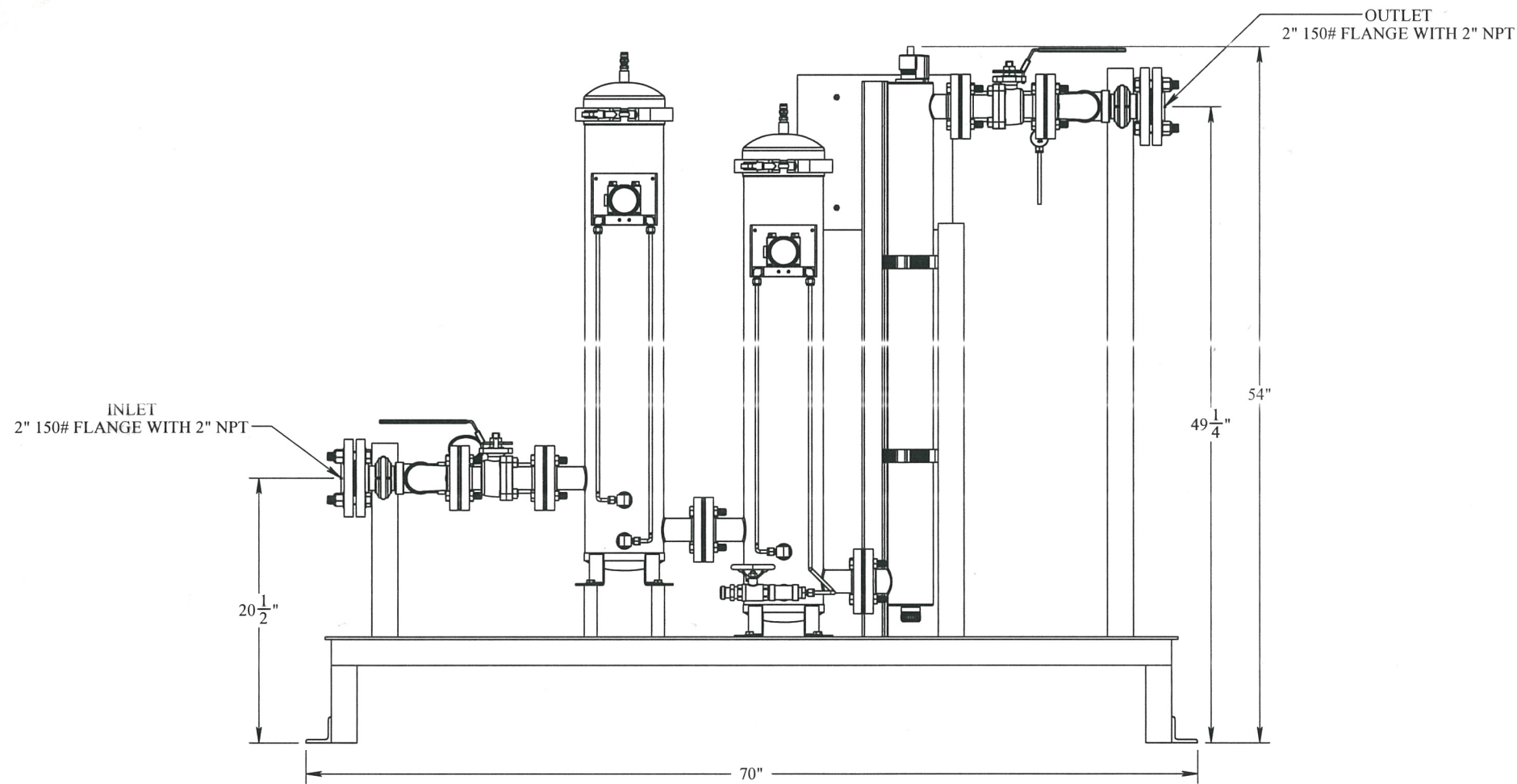
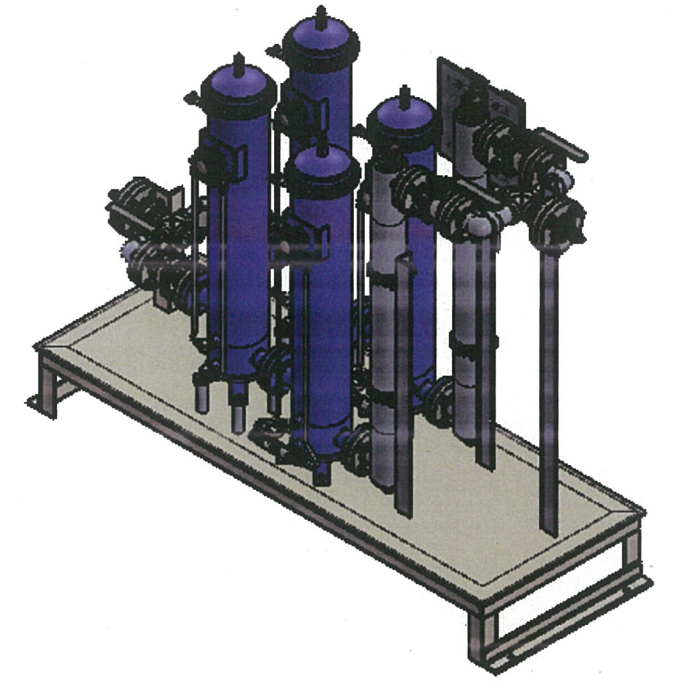
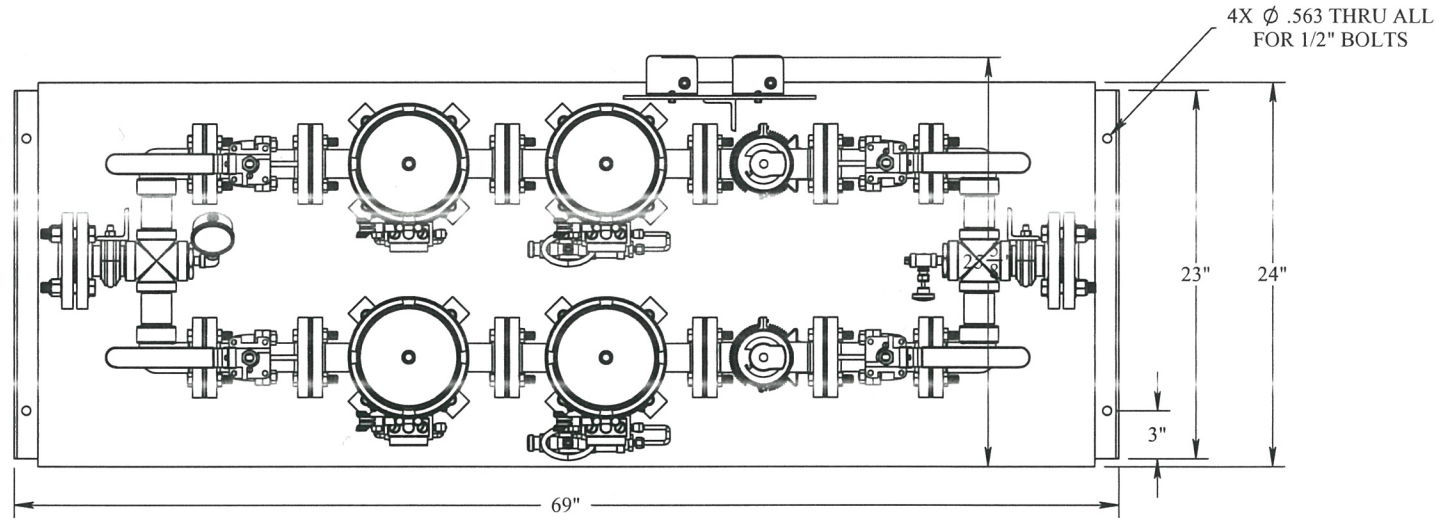
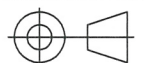

NOTE:
THIS IS A GUIDANCE DRAWING AND NOT "AS BUILT". DIMENSIONS MAY VARY.

PROPRIETARY AND CONFIDENTIAL:
THE INFORMATION CONTAINED IN THIS DRAWING IS THE SOLE PROPERTY OF THE SUBSEA COMPANY INC. ANY REPRODUCTION IN PART OR AS A WHOLE WITHOUT THE WRITTEN PERMISSION OF THE SUBSEA COMPANY INC IS PROHIBITED.

3RD ANGLE PROJECTION:



INTERPRET GEOMETRIC TOLERANCING PER: ASME Y14.5

WORKMANSHIP STANDARD PER WI 751-001

UNLESS OTHERWISE SPECIFIED:
ALL DIMENSIONS ARE IN INCHES

WEIGHT: 349.184 LBS.

	NAME	DATE
DRAWN	TLC	4-5-21
CHECKED	TC	4-5-21
APPROVED	KAC	4-5-21

 THE SUBSEA COMPANY INC		REV
		A1
SIZE	TITLE:	
B	BOP WATER SUPPLY FILTRATION WITH UV	
DWG. NO. TSC-02748-GA		SHEET 1 OF 1