

TSC-02279-SK SPARES KIT, FLUID FILTRATION PANEL WITH PUMP		
PART NUMBER	DESCRIPTION	QTY.
SE-1847	FILTER, 12 MICRON, 4-1/2"X30", MELT BLOWN POLYPROPYLENE	1
SE-1846	FILTER, 3 MICRON, 4-1/2"X30", MELT BLOWN POLYPROPYLENE	1
SE-1210	FUSE, TIME LAG, 30A, CLASS CC, 600/300 VAC/VDC	2
SE-1288	FUSE, 5 x 20 mm CARTRIDGE, 5 AMPS, 250 VAC FAST ACTING	2
SE-0832-1	GAUGE, DIFFERENTIAL, FILTER COND., W/ MOUNTING BASE	1

REVISIONS				
REV.	DESCRIPTION	ECO #	DATE	APPROVED
A1	RELEASE	2017-067	7/11/2017	

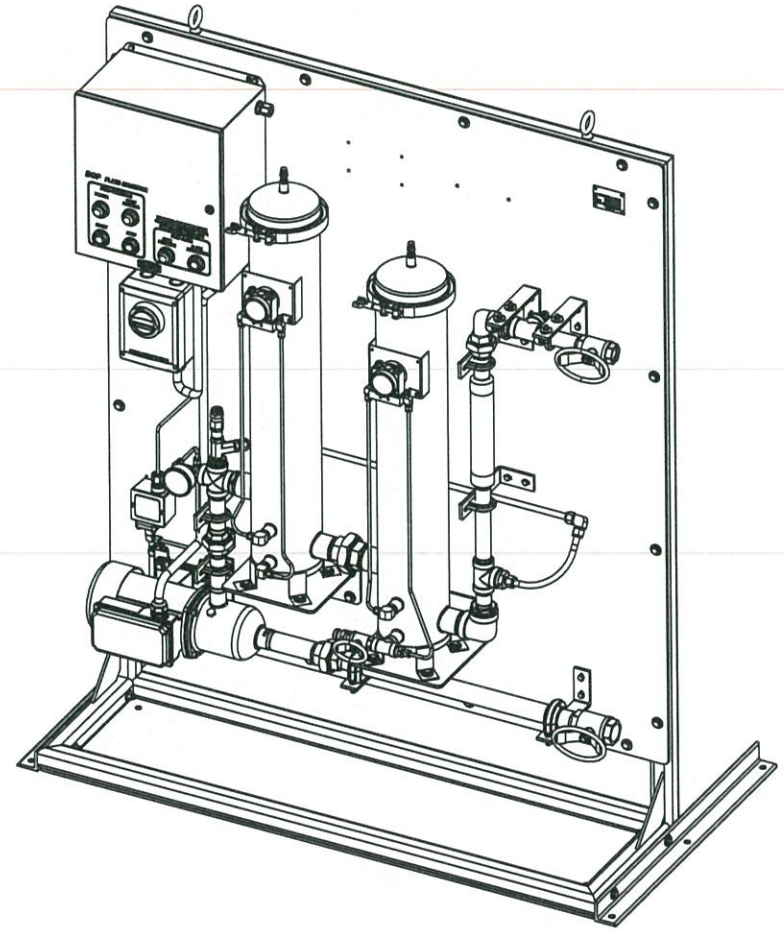
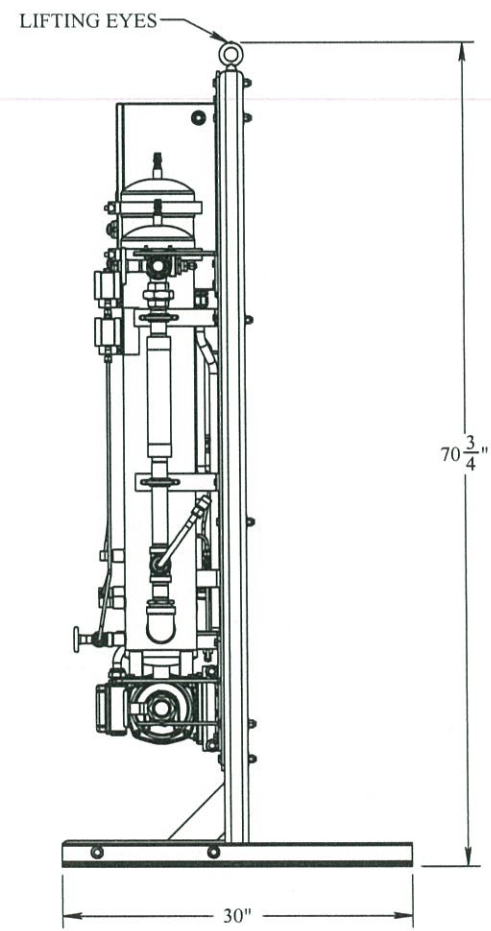
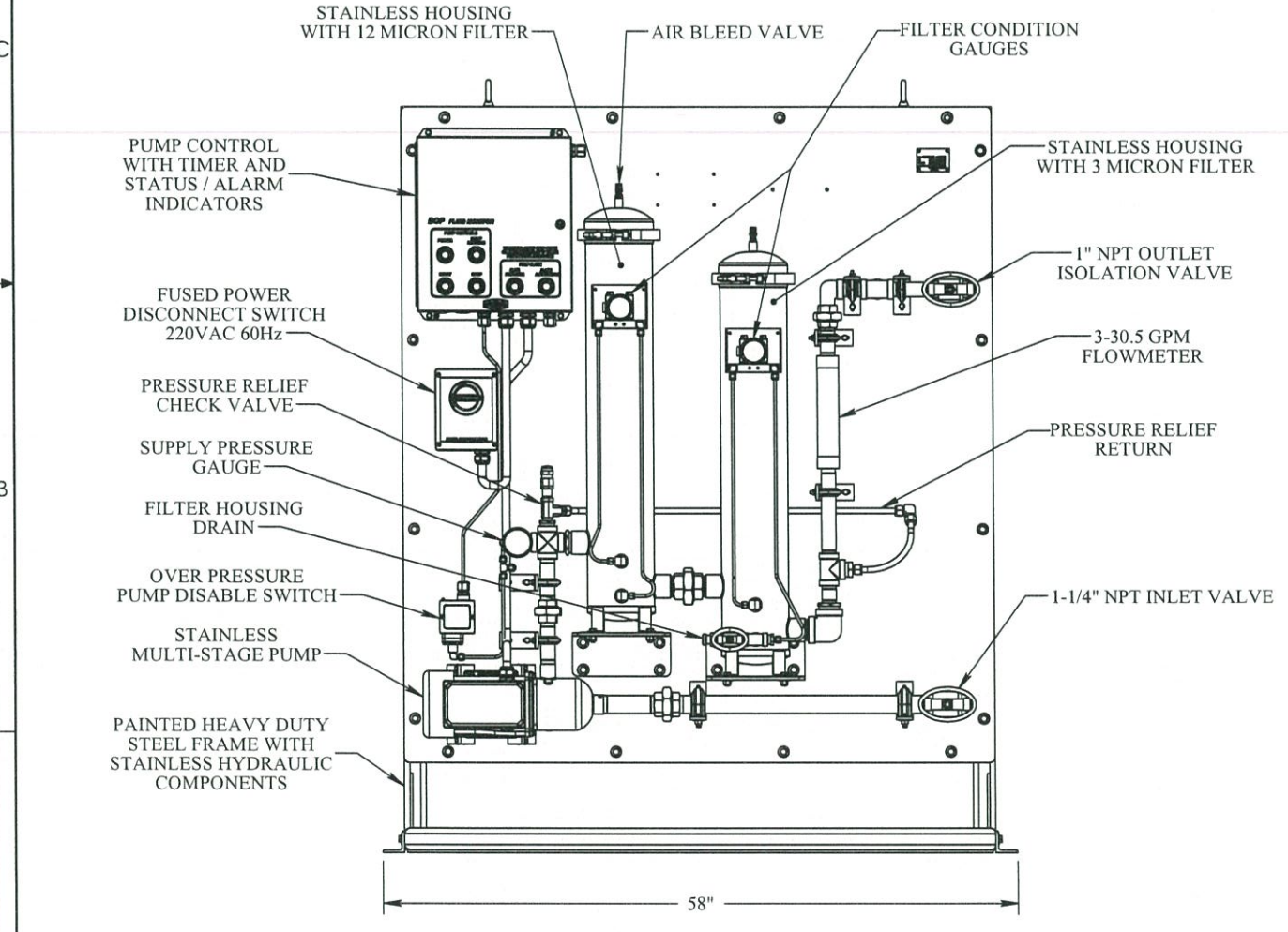
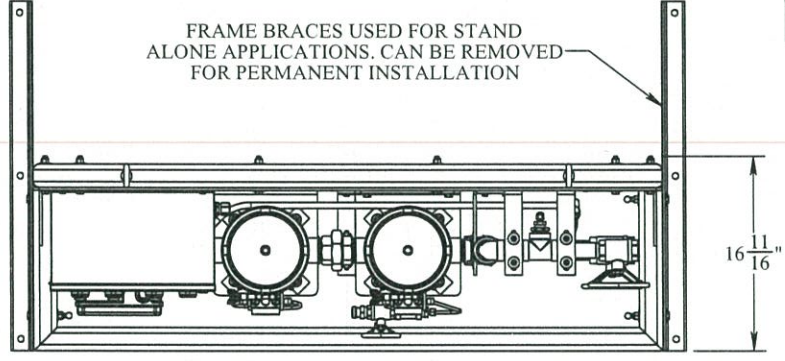

**FEATURES:**

- PUMP CONTROL WITH TIMER AND STATUS / ALARM INDICATORS
- FUSED POWER DISCONNECT SWITCH, 220VAC, SINGLE PHASE, 60Hz
- MULTI-STAGE STAINLESS STEEL PUMP
- DUAL FILTER HOUSINGS, 12 MICRON PRE FILTER, 3 MICRON POST FILTER
- FILTER CONDITION GAUGES
- 3 - 30.5 GPM FLOWMETER
- SUPPLY PRESSURE GAUGE
- OVER PRESSURE BYPASS CHECK VALVE
- OVER PRESSURE PUMP DISABLE SWITCH
- 1-1/4" NPT INLET CONNECTION, 1" NPT OUTLET CONNECTION
- 100 PSI MAXIMUM WORKING PRESSURE
- PAINTED HEAVY DUTY FRAME WITH STAINLESS HYDRAULIC COMPONENTS

**PROPRIETARY AND CONFIDENTIAL:**  
 THE INFORMATION CONTAINED IN THIS DRAWING IS THE SOLE PROPERTY OF THE SUBSEA COMPANY INC. ANY REPRODUCTION IN PART OR AS A WHOLE WITHOUT THE WRITTEN PERMISSION OF THE SUBSEA COMPANY INC IS PROHIBITED.

3RD ANGLE PROJECTION:

INTERPRET GEOMETRIC TOLERANCING PER: ASME Y14.5

WORKMANSHIP STANDARD PER WI 751-001

UNLESS OTHERWISE SPECIFIED: ALL DIMENSIONS ARE IN INCHES

WEIGHT: 760.59 LBS.

	NAME	DATE
DRAWN	Corly	1-28-17
CHECKED	RK	7-28-17
APPROVED	Ron	7-28-17

**THE SUBSEA COMPANY** THE SUBSEA COMPANY INC

SIZE: **B** TITLE: FLUID FILTRATION PANEL, WITH PUMP

DWG. NO. TSC-02279-GA

REV **A1** SHEET 1 OF 1