

8 7 6 5 4 3 2 1

REVISIONS				
REV.	DESCRIPTION	ECO #	DATE	APPROVED
A1	RELEASE	2014-176	5/29/2014	CMB

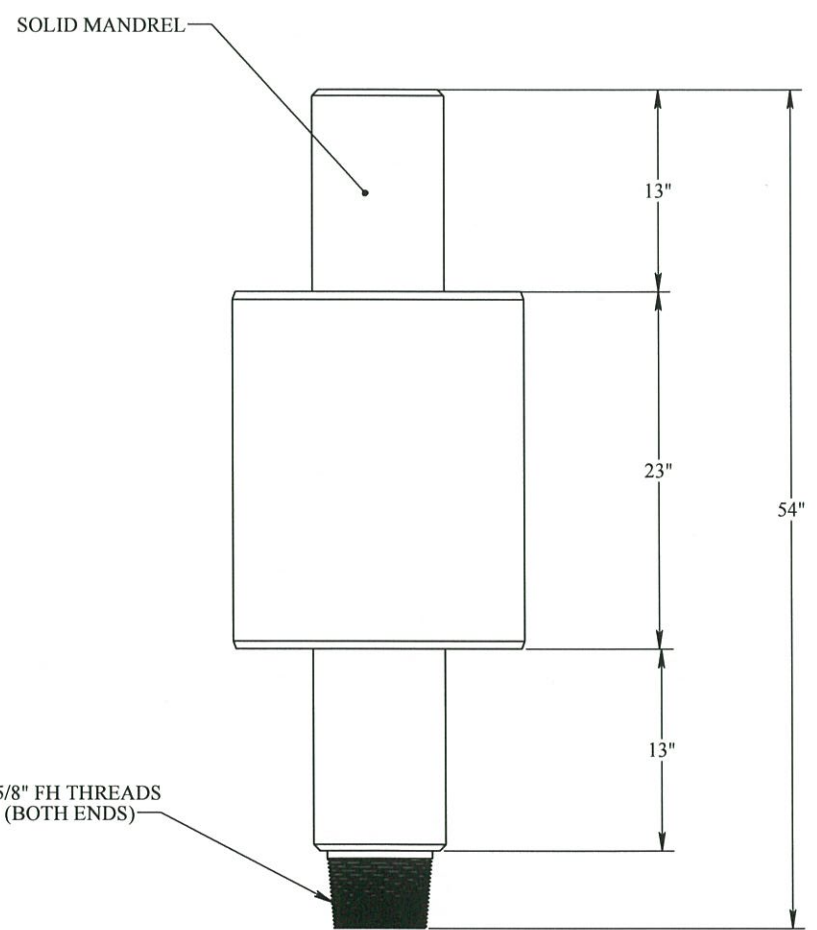
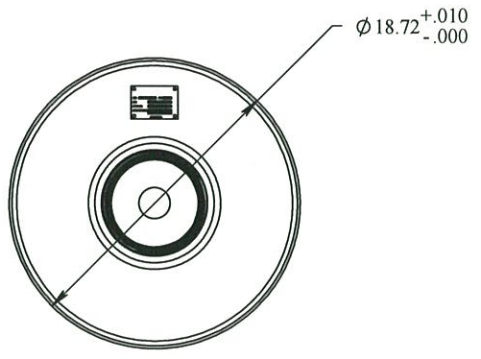

**DRIFT FEATURES**

1. OUTSIDE DIAMETER 18.720 +.010-.000
2. 6-5/8" FH BOX x PIN
3. DESIGNED IAW WITH API SPECIFICATION 7, MEETS OR EXCEEDS REQUIREMENTS OF TABLE 7
4. MAKE-UP WITH CHAIN TONGS
5. WORKING LOAD 10,000 LBS
6. PULL TESTED TO 15,000 LBS
7. APPROXIMATE WEIGHT: 1263 LBS
8. MILD STEEL CONSTRUCTION (36 KSI)
9. DRIFT IS DESIGNED FOR SURFACE TESTING ONLY

**PROPRIETARY AND CONFIDENTIAL:**  
 THE INFORMATION CONTAINED IN THIS DRAWING IS THE SOLE PROPERTY OF THE SUBSEA COMPANY INC. ANY REPRODUCTION IN PART OR AS A WHOLE WITHOUT THE WRITTEN PERMISSION OF THE SUBSEA COMPANY INC IS PROHIBITED.

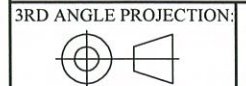

INTERPRET GEOMETRIC TOLERANCING PER: ASME Y14.5

WORKMANSHIP STANDARD PER WI 751-001

UNLESS OTHERWISE SPECIFIED: ALL DIMENSIONS ARE IN INCHES

	NAME	DATE
DRAWN	BPS	5/27/14
CHECKED	GREG	6-0-14
Q.A.		
MFG APPR.	TIPAN	6-12-14

**THE SUBSEA COMPANY** THE SUBSEA COMPANY INC

SIZE <b>B</b>	TITLE: DRIFT, 18-3/4" API, 23" BODY, 6-5/8" FH BOX x PIN	REV <b>A1</b>
------------------	---	------------------

8 7 6 5 4 3 2 1