

8 7 6 5 4 3 2 1

REVISIONS				
REV.	DESCRIPTION	ECO #	DATE	APPROVED
A1	RELEASE	2014-171	5/23/14	GJB

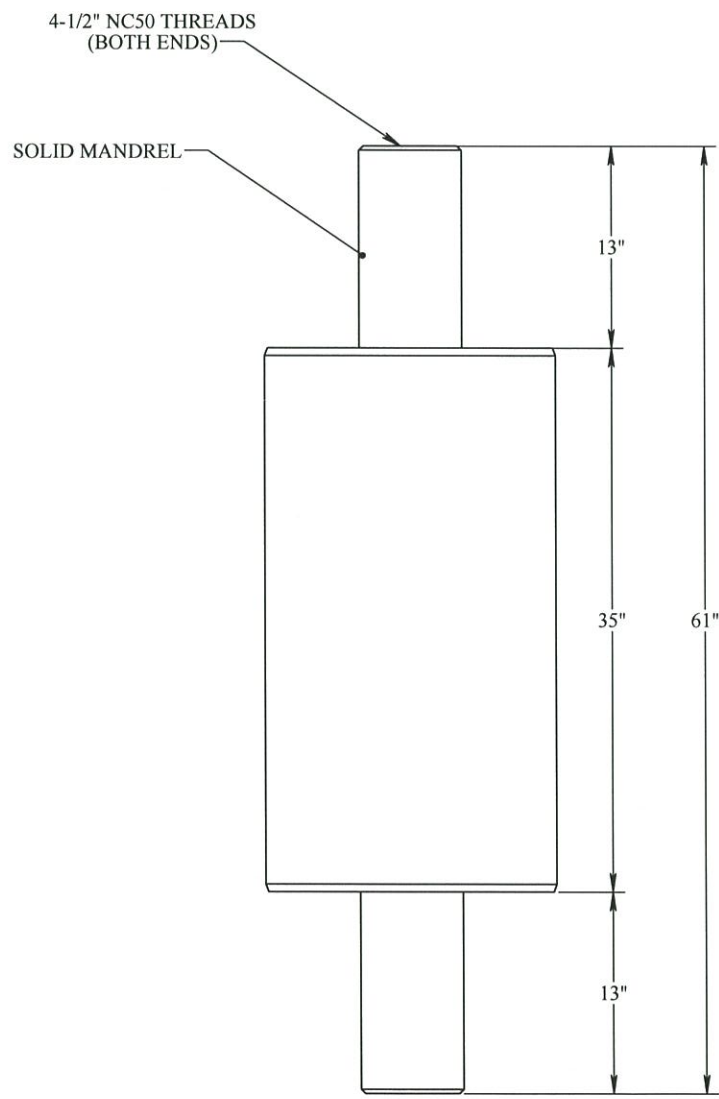
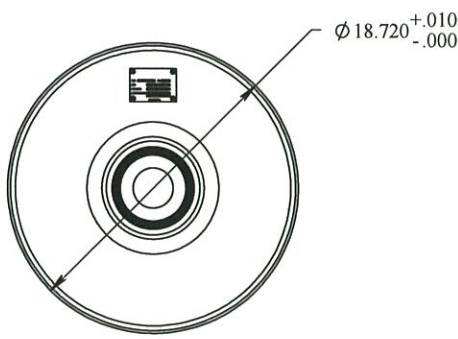

**DRIFT FEATURES**

1. OUTSIDE DIAMETER 18.720 +.010-.000
2. 4-1/2" NC50 BOX x BOX
3. DESIGNED IAW WITH API SPECIFICATION 7, MEETS OR EXCEEDS REQUIREMENTS OF TABLE 7
4. MAKE-UP WITH CHAIN TONGS
5. WORKING LOAD 10,000 LBS
6. PULL TESTED TO 15,000 LBS
7. APPROXIMATE WEIGHT: 1493 LBS
8. MILD STEEL CONSTRUCTION (36 KSI)
9. DRIFT IS DESIGNED FOR SURFACE TESTING ONLY

**PROPRIETARY AND CONFIDENTIAL:**  
 THE INFORMATION CONTAINED IN THIS DRAWING IS THE SOLE PROPERTY OF THE SUBSEA COMPANY INC. ANY REPRODUCTION IN PART OR AS A WHOLE WITHOUT THE WRITTEN PERMISSION OF THE SUBSEA COMPANY INC IS PROHIBITED.

3RD ANGLE PROJECTION:

INTERPRET GEOMETRIC TOLERANCING PER: ASME Y14.5

WORKMANSHIP STANDARD PER WI 751-001

UNLESS OTHERWISE SPECIFIED: ALL DIMENSIONS ARE IN INCHES

	NAME	DATE
DRAWN	TLC	5/23/14
CHECKED	GREG	6-9-14
Q.A.	Ross	6/11/14
MFG APPR.	TIPON	6/12/14



**THE SUBSEA COMPANY INC**

SIZE <b>B</b>	TITLE: DRIFT, 18-3/4" API, 35" BODY, 4-1/2" NC50 BOX x BOX	REV <b>A1</b>
------------------	---	------------------

DO NOT SCALE DRAWING

DWG. NO. TSC-02119-GA

SHEET 1 OF 1

8 7 6 5 4 3 2 1